

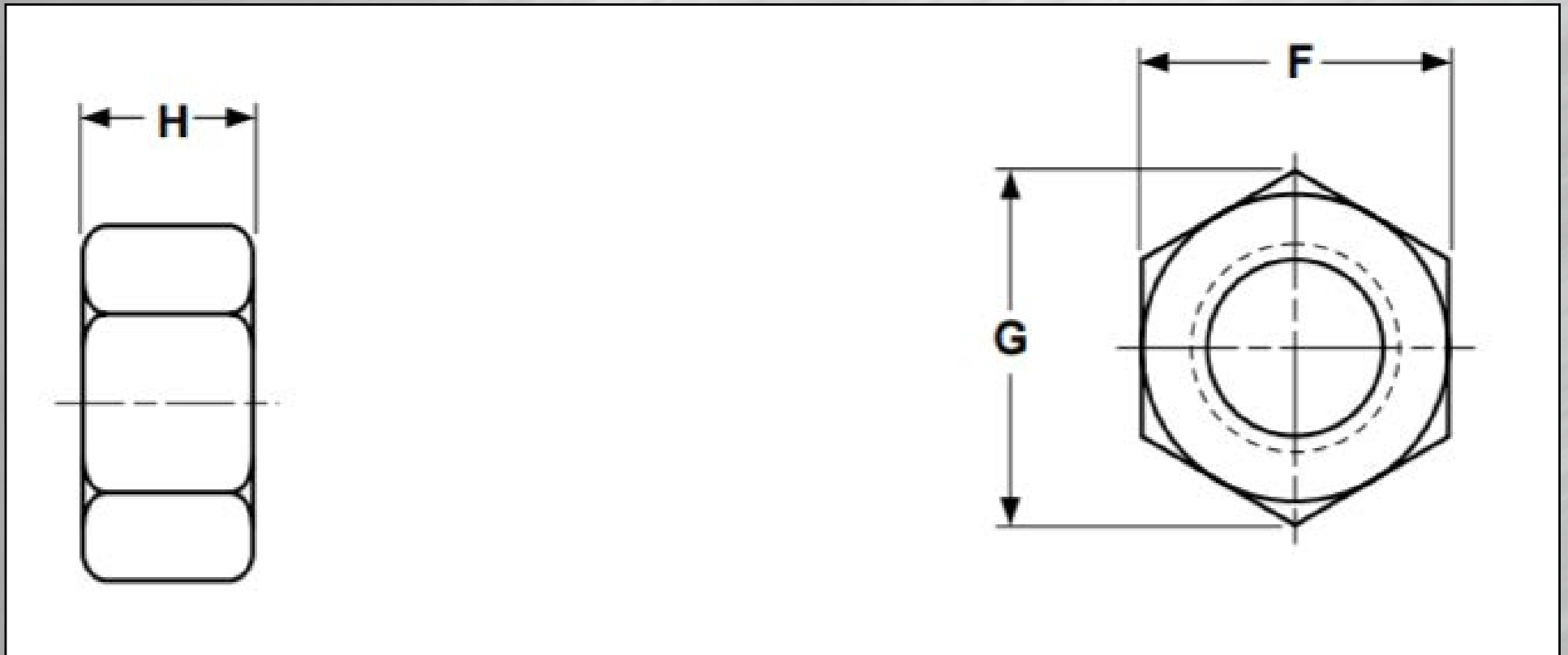

545 Basket Road • Webster, NY 14580
Toll Free • 800.691.0292 | Local • 585.265.1990 | Fax • 585.265.6678
sales@fastenersdirect.com
www.fastenersdirect.com

HEX NUTS - GRADE 5 & 8 ZINC PLATED (DOMESTIC)

FINE THREADED





545 Basket Road • Webster, NY 14580
 Toll Free • 800.691.0292 | Local • 585.265.1990 | Fax • 585.265.6678
 sales@fastenersdirect.com
 www.fastenersdirect.com

HEX NUTS - GRADE 5 & 8 ZINC PLATED (DOMESTIC) FINE THREADED

Nominal or Basic Major Diameter of Thread	F Width Across Flats			G Width Across Corners		H Thickness of Hex Nuts			
	Basic	Max	Min	Max	Min	Basic	Max	Min	
1/4	0.2500	7/16	0.438	0.428	0.505	0.488	7/32	0.226	0.212
5/16	0.3125	1/2	0.500	0.489	0.577	0.557	17/64	0.273	0.258
3/8	0.3750	9/16	0.562	0.551	0.650	0.628	21/64	0.337	0.320
7/16	0.4375	11/16	0.688	0.675	0.794	0.768	3/8	0.385	0.365
1/2	0.5000	3/4	0.750	0.736	0.866	0.840	7/16	0.448	0.427
9/16	0.5625	7/8	0.875	0.861	1.010	0.982	31/64	0.496	0.473
5/8	0.6250	15/16	0.938	0.922	1.083	1.051	35/64	0.559	0.535
3/4	0.7500	1-1/8	1.125	1.088	1.299	1.240	41/64	0.665	0.617
7/8	0.8750	1-5/16	1.312	1.269	1.516	1.447	3/4	0.776	0.724
1	1.1000	1-1/2	1.500	1.450	1.732	1.653	55/64	0.887	0.831
1-1/8	1.1250	1-11/16	1.688	1.631	1.949	1.859	31/32	0.999	0.939
1-1/4	1.2500	1-7/8	1.875	1.812	2.165	2.066	1-1/16	1.094	1.030
1-3/8	1.3750	2-1/16	2.062	1.994	2.382	2.273	1-11/64	1.206	1.138
1-1/2	1.5000	2-1/4	2.250	2.175	2.598	2.480	1.935	1.317	1.245



545 Basket Road • Webster, NY 14580
 Toll Free • 800.691.0292 | Local • 585.265.1990 | Fax • 585.265.6678
 sales@fastenersdirect.com
 www.fastenersdirect.com

HEX NUTS - GRADE 5 & 8 ZINC PLATED (DOMESTIC) FINE THREADED

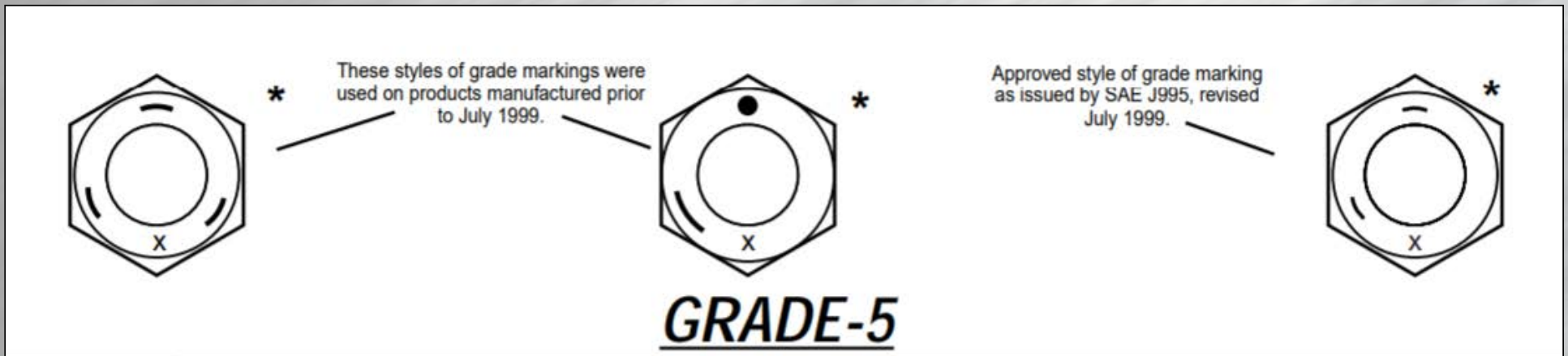

Description	A finished hex nut made from steel with a maximum carbon content of 0.55%, a minimum manganese content of 0.30% and a maximum sulfur content of 0.15%
Applications / Advantages	For use with bolts with a minimum tensile strength equal to or less than the specified proof stress of the nut.
Material	AISI 1008 - 1026 or equivalent steel
Core Hardness	Rockwell C32 Maximum
Proof Load	1/4 through 1 in. <u>Coarse Thread</u> : 120,000 psi; <u>Fine Thread</u> : 109,000 psi 1-1/8 through 1-1/2 in. <u>Coarse Thread</u> : 105,000 psi; <u>Fine Thread</u> : 94,000 psi

HEX NUTS - GRADE 5 & 8 ZINC PLATED (DOMESTIC)

FINE THREADED

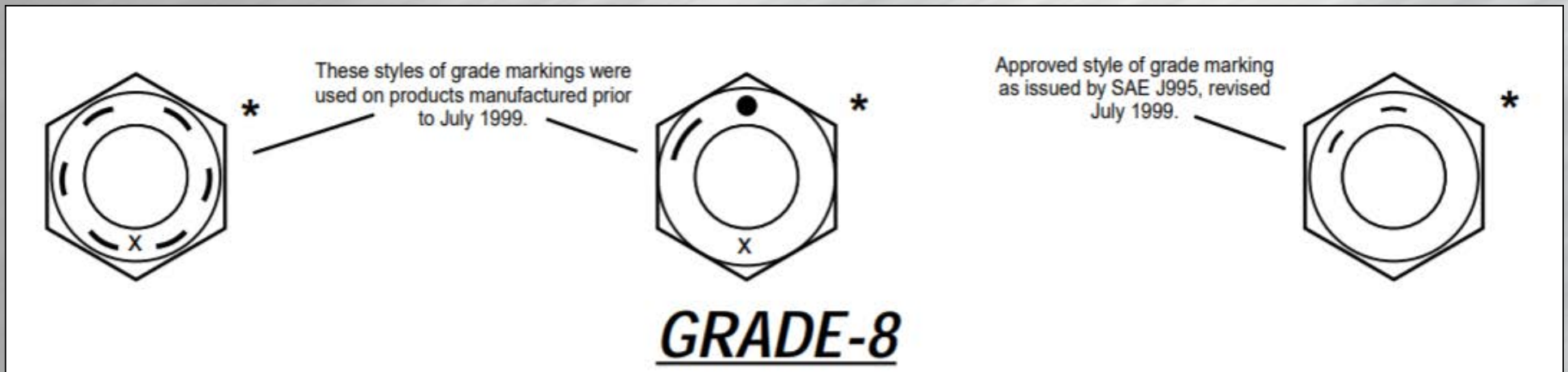

Description	A finished hex nut made from steel with a maximum carbon content of .55%, a minimum manganese content of 0.30% and a maximum sulfur content of 0.05%. The purchaser and producer of the nuts may agree to allow a sulfur content of 0.33% maximum provided that the manganese content is at least 1.35%
Applications / Advantages	For use with bolts with a minimum tensile strength equal to or less than 150,000 psi.
Material	AISI 1021 -1045 or equivalent steel
Core Hardness	1/4 through 5/8 in: Rockwell C24 - C32 3/4 through 1 in: Rockwell C26 - C34 Over 1 in. through 1-1/2 in: Rockwell C26 - C36
Proof Load	1/4 through 1-1/2 in: 150,000 psi